



US006295744B1

(12) **United States Patent**
Ellis, III

(10) **Patent No.:** **US 6,295,744 B1**
(45) **Date of Patent:** ***Oct. 2, 2001**

- (54) **SHOE SOLE STRUCTURES**
- (75) **Inventor:** **Frampton E. Ellis, III, Arlington, VA (US)**
- (73) **Assignee:** **Anatomic Research, Inc., Arlington, VA (US)**
- (*) **Notice:** Subject to any disclaimer, the term of this patent is extended or adjusted under 35 U.S.C. 154(b) by 0 days.

This patent is subject to a terminal disclaimer.

4,542,598	*	9/1985	Misevich et al.	36/114
4,547,979	*	10/1985	Harada et al.	36/30 R
4,570,362	*	2/1986	Vernonet	36/59 C
4,624,061	*	11/1986	Wezel et al.	36/31
4,638,577	*	1/1987	Riggs	36/32 R
4,654,983	*	4/1987	Graham et al.	36/30 R
4,667,423	*	5/1987	Autry et al.	36/30 R
4,715,133	*	12/1987	Hartjes et al.	36/127
4,724,622	*	2/1988	Mills	36/32 R
4,731,939	*	3/1988	Parracho et al.	36/31
4,748,753	*	6/1988	Ju	36/127
4,777,738	*	10/1988	Giese et al.	36/32 R
4,783,910	*	11/1988	Boys, II et al.	36/30 R
4,858,340	*	8/1989	Pasternak	36/30 R
4,864,737	*	9/1989	Marrello	36/29

- (21) **Appl. No.:** **08/390,288**
- (22) **Filed:** **Feb. 15, 1995**

(List continued on next page.)

Related U.S. Application Data

FOREIGN PATENT DOCUMENTS

- (63) Continuation of application No. 08/053,321, filed on Apr. 27, 1993, now abandoned, which is a continuation of application No. 07/539,870, filed on Jun. 18, 1990, now abandoned.
- (51) **Int. Cl.⁷** **A43B 13/14**
- (52) **U.S. Cl.** **36/114; 36/25 R; 36/30 R**
- (58) **Field of Search** **36/59 C, 59 R, 36/32 R, 28, 29, 114, 116, 12, 107, 108, 76 R, 25 R, 30 R**

1209844	*	3/1969	(DE)	36/25 R
9591	*	11/1918	(GB)	36/25 R
8303528	*	10/1983	(WO)	36/32 R

Primary Examiner—M. D. Patterson
(74) *Attorney, Agent, or Firm*—Finnegan, Henderson, Farabow, Garrett & Dunner, L.L.P.

(56) **References Cited**

(57) **ABSTRACT**

U.S. PATENT DOCUMENTS

500,385	*	6/1893	Hall	36/103
2,124,986	*	7/1938	Pipes	36/59 C
2,155,166	*	4/1939	Kraft	36/32 R
2,206,860	*	7/1940	Sperry	36/59 C
2,345,831	*	4/1944	Pierson	36/33
3,087,261	*	4/1963	Russell	36/28
3,824,716	*	7/1974	DiPaolo	36/30 R
3,834,046	*	9/1974	Fowler	36/30 R
4,059,910	*	11/1977	Bryden et al.	36/103
4,302,892	*	12/1981	Adamik	36/31
4,309,832	*	1/1982	Hunt	36/32 R
4,455,767	*	6/1984	Bergmans	36/14

A construction for a shoe, particularly an athletic shoe, which includes a sole that conforms to the natural shape of the foot shoe, including the bottom and the sides, when that foot sole deforms naturally by flattening under load while walking or running in order to provide a stable support base for the foot and ankle. Deformation sipes such as slits or channels are introduced in horizontal plane of the shoe sole to provide it with flexibility roughly equivalent to that of the foot. The result is a shoe sole that accurately parallels the frontal plane deformation of the foot sole, which creates a stable base that is wide and flat even when tilted sideways in extreme pronation or supination motion. In marked contrast, conventional shoe soles are rigid and become highly unstable when tilted sideways because they are supported only by a thin bottom edge.

17 Claims, 7 Drawing Sheets

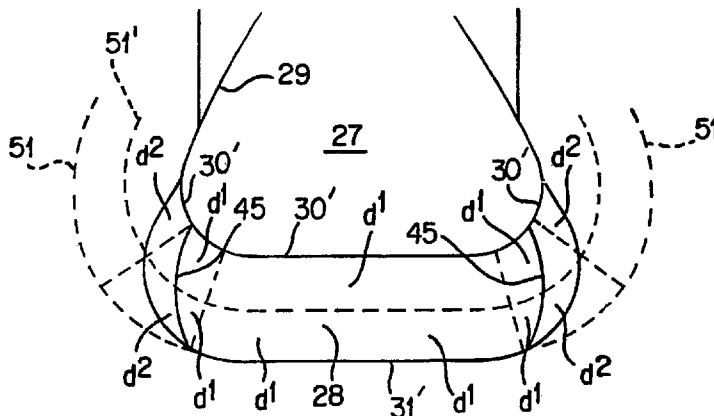

US 6,295,744 B1

Page 2

U.S. PATENT DOCUMENTS

				5,048,203	*	9/1991	Kling	36/59	C
4,890,398	*	1/1990	Thomasson					36/59	C
4,894,932	*	1/1990	Harada et al.					36/30	R
5,012,597	*	5/1991	Thomasson					36/59	C
5,014,449	*	5/1991	Richard et al.					36/30	R
5,025,573	*	6/1991	Giese et al.					36/30	R
				5,224,810	*	7/1993	Pitkin	36/30	R
				5,247,742	*	9/1993	Kilgore	36/114	
				5,317,819	*	6/1994	Ellis, III	36/25	R

* cited by examiner

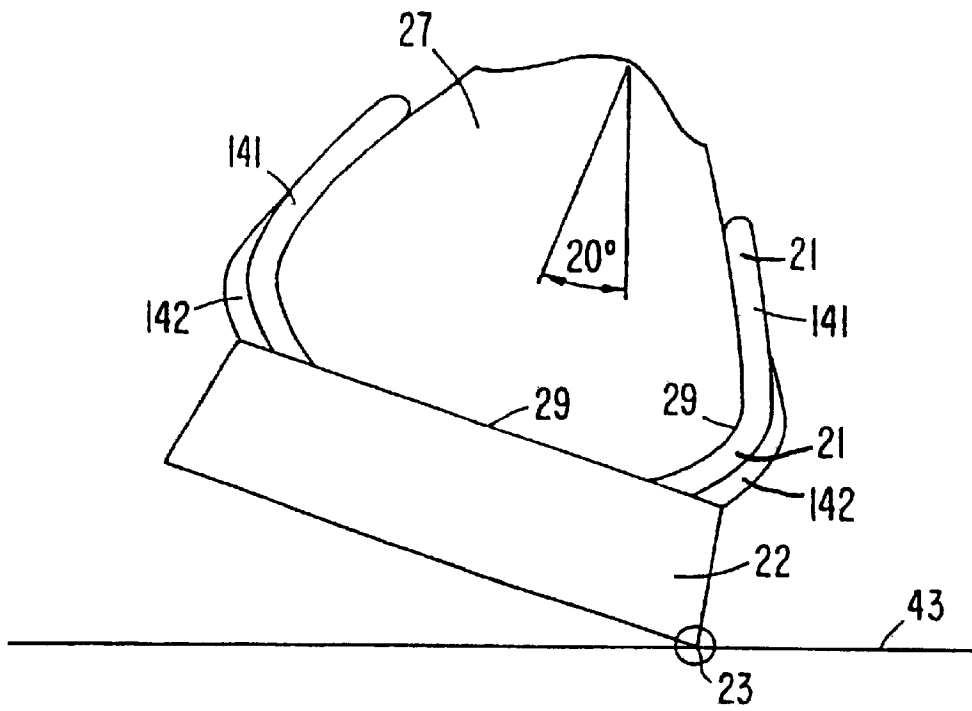

FIG. 1

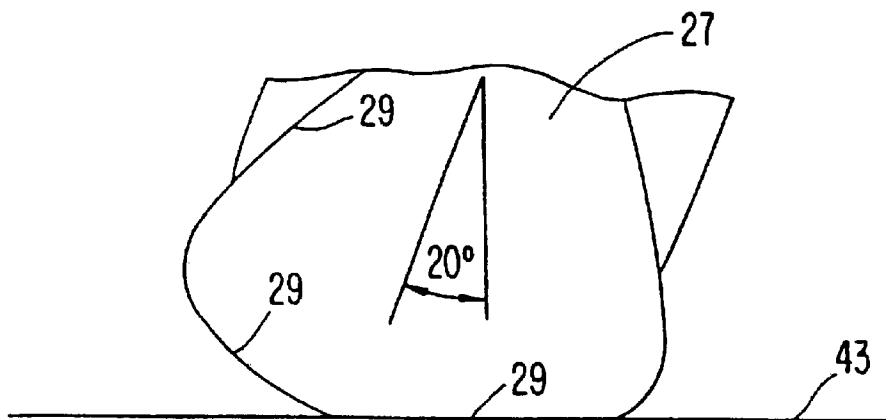

FIG. 2

FIG. 3

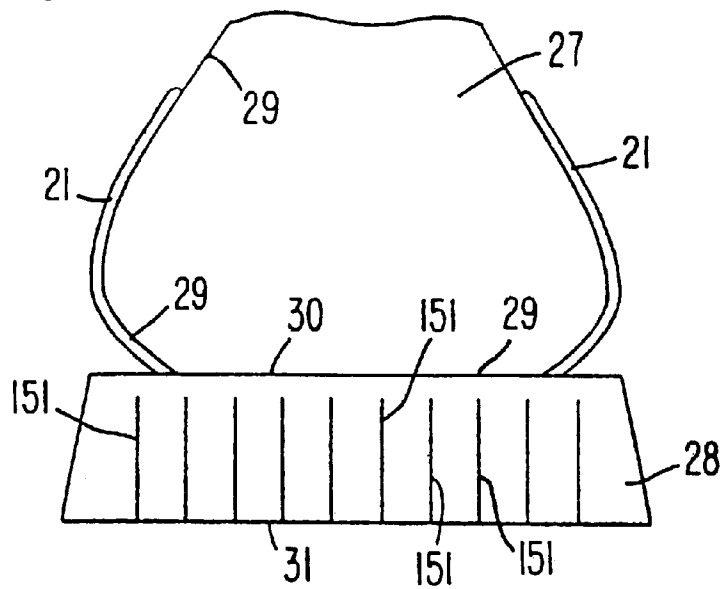
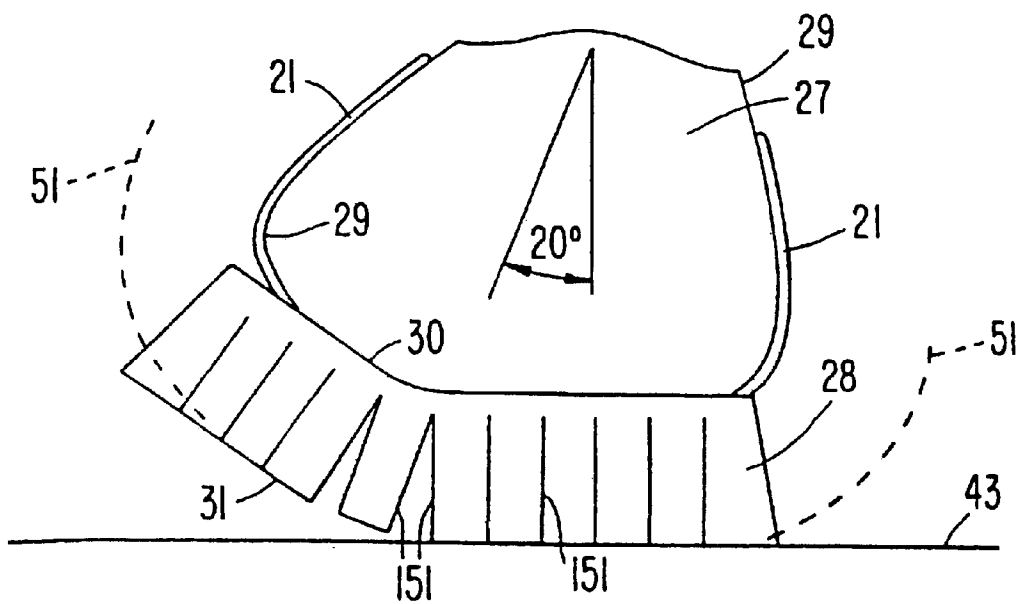

FIG. 4



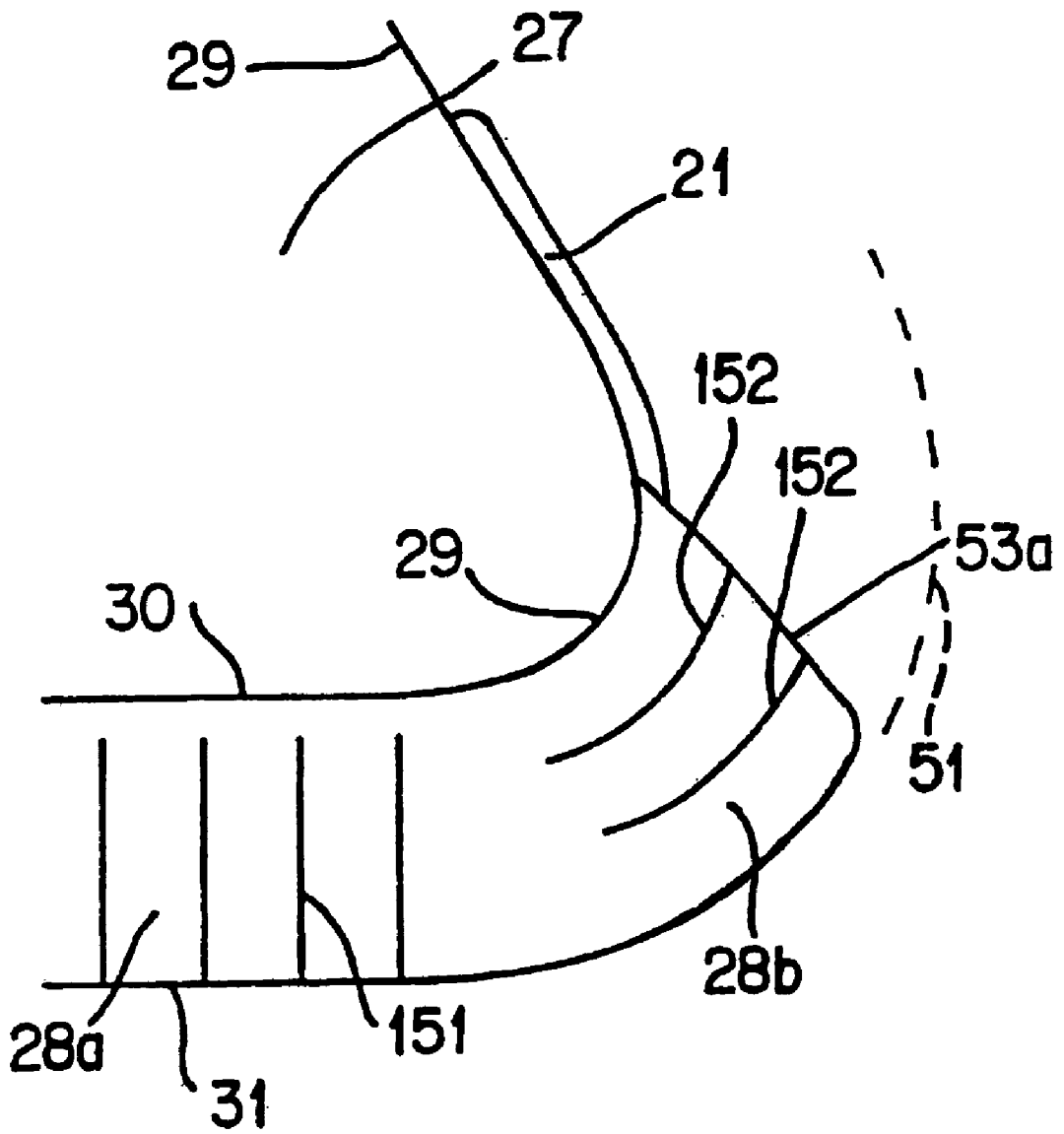

FIG. 5

FIG. 6A

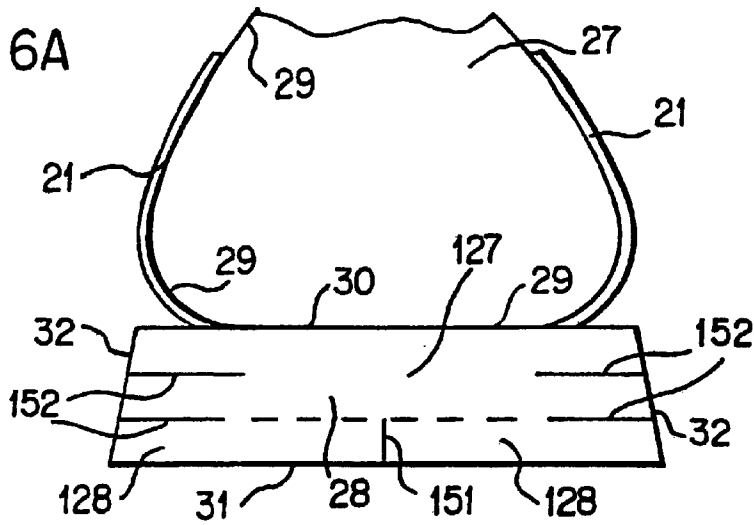

FIG. 6B

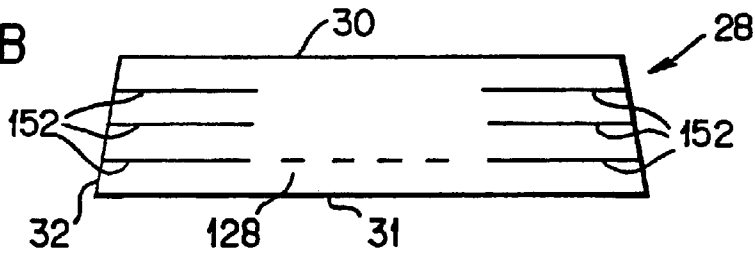

FIG. 6C

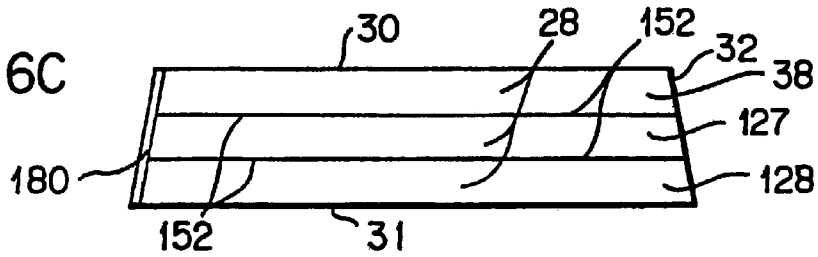

FIG. 7

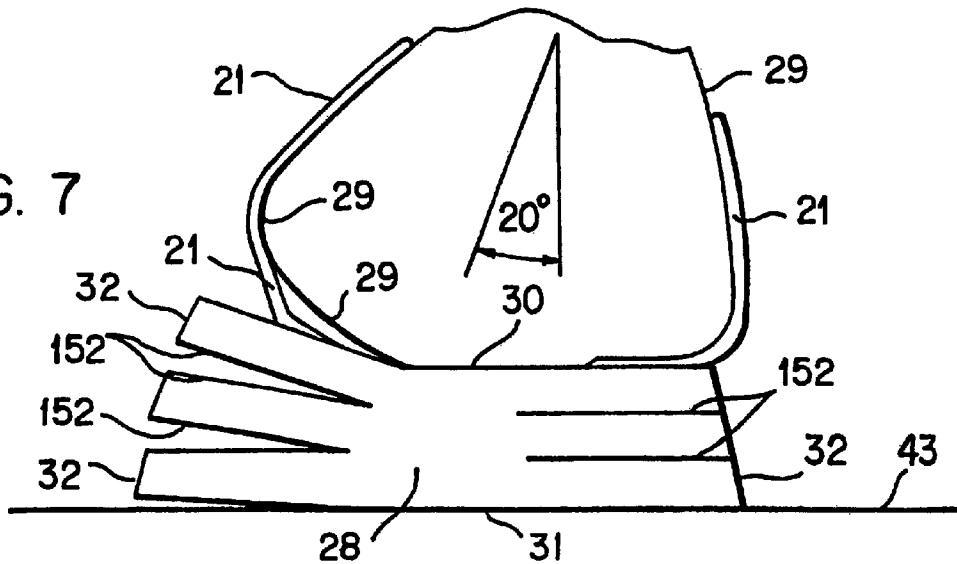

FIG. 8

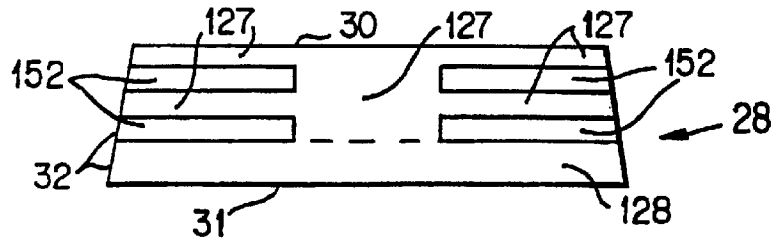

FIG. 9B

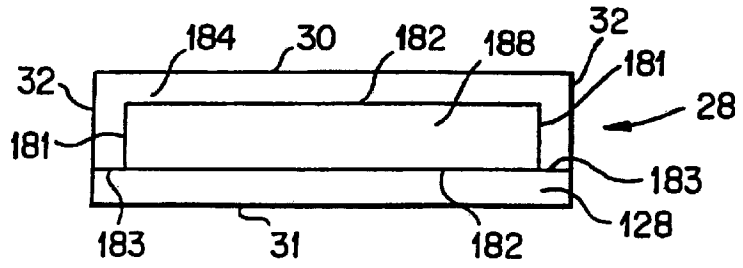

FIG. 9C

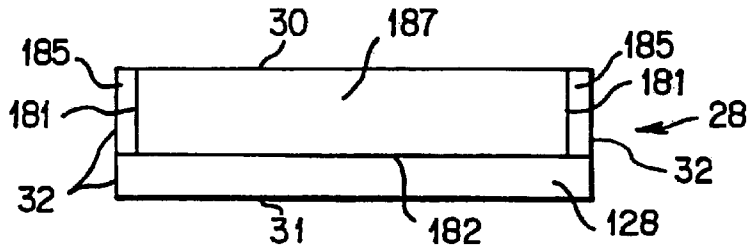

FIG. 9A

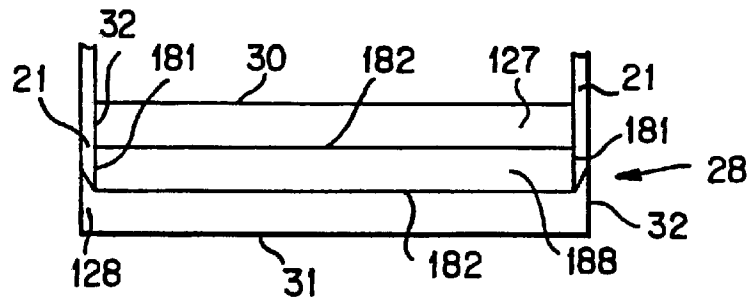

FIG. 9D

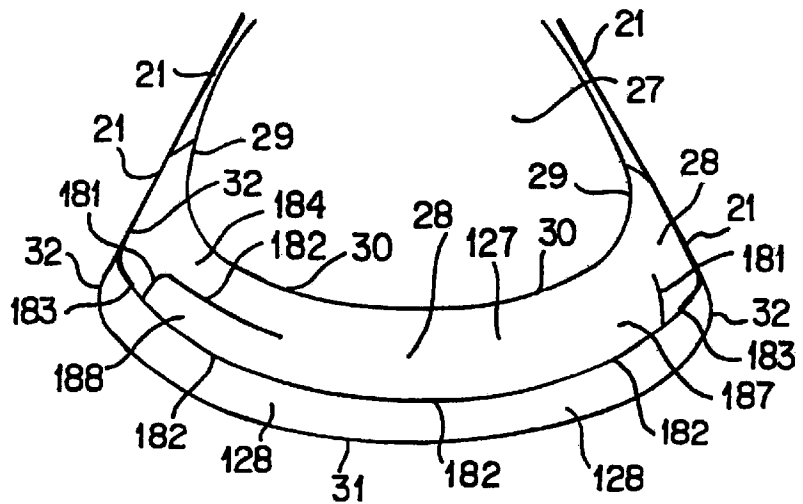

FIG. 10

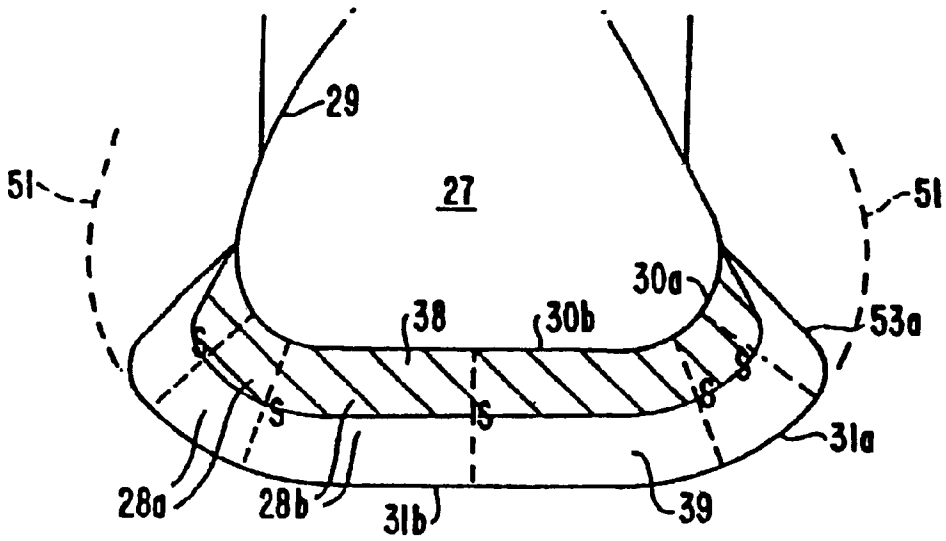
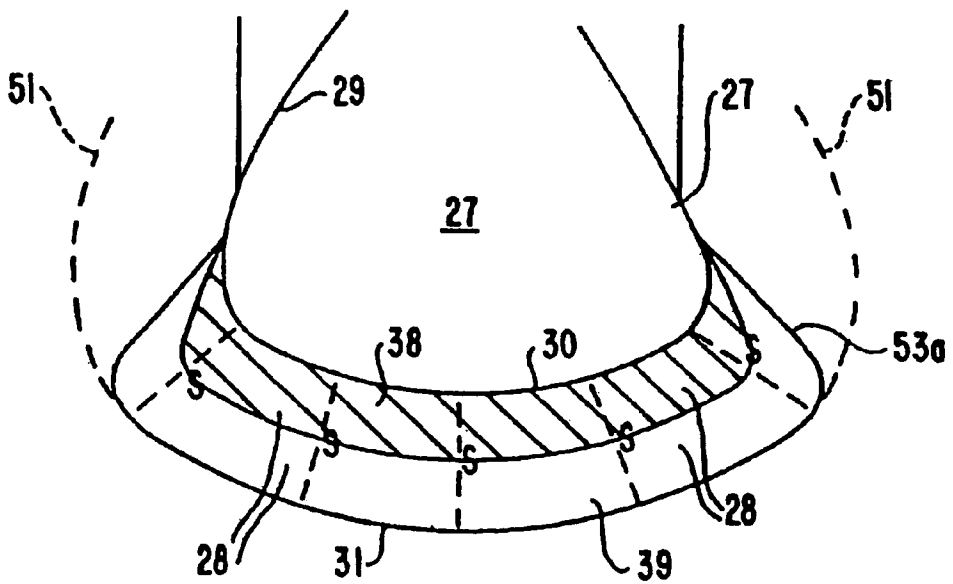

FIG. 11



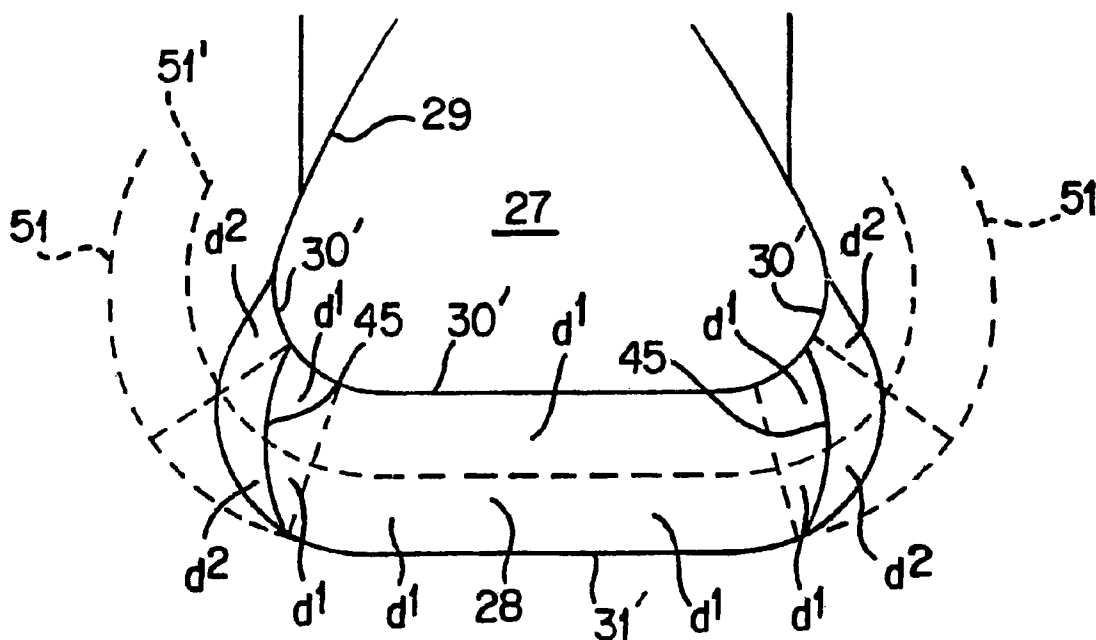

FIG. 12

SHOE SOLE STRUCTURES

This application is a continuation of application Ser. No. 08/053,321, filed Apr. 27, 1993, now abandoned, which is a continuation of application Ser. No. 07/539,870, filed Jun. 18, 1990, now abandoned.

BACKGROUND OF THE INVENTION

This invention relates generally to the structure of shoes. More specifically, this invention relates to the structure of athletic shoes. Still more particularly, this invention relates to shoe soles that conform to the natural shape of the foot sole, including the bottom and the sides, when the foot sole deforms naturally during locomotion in order to provide a stable support base for the foot and ankle. Still more particularly, this invention relates to the use of deformation sipes such as slits or channels in the shoe sole to provide it with sufficient flexibility to parallel the frontal plane deformation of the foot sole, which creates a stable base that is wide and flat even when tilted sideways in natural pronation and supination motion.

The applicant has introduced into the art the use of sipes to provide natural deformation paralleling the human foot in pending U.S. application Ser. No. 07/424,509, filed Oct. 20, 1989, and No. 07/478,579, filed Feb. 8, 1990. It is the object of this invention to elaborate upon those earlier applications to apply their general principles to other shoe sole structures, including those introduced in other earlier applications.

By way of introduction, the prior two applications elaborated almost exclusively on the use of sipes such as slits or channels that are preferably about perpendicular to the horizontal plane and about parallel to the sagittal plane, which coincides roughly with the long axis of the shoe; in addition, the sipes originated generally from the bottom of the shoe sole. This application will elaborate on use of sipes that instead originate generally from either or both sides of the shoe sole and are preferably about perpendicular to the sagittal plane and about parallel to the horizontal plane; that approach was introduced in the '509 application. Thus, this application will focus on sipes originating generally from either or both sides of the shoe sole, rather than from the bottom or top (or both) of the shoe sole.

In addition to the prior pending applications indicated above, the applicant has introduced into the art the concept of a theoretically ideal stability plane as a structural basis for shoe sole designs. That concept as implemented into shoes such as street shoes and athletic shoes is presented in U.S. Pat. No. 4,989,349, issued Feb. 5, 1991 and Number 5,317,819, issued Jun. 7, 1994, and in pending U.S. applications Nos. 07/400,714, filed on Aug. 30, 1989; 07/416,478, filed on Oct. 3, 1989; 07/463,302, filed on Jan. 10, 1990; and 07/469,313, filed on Jan. 24, 1990, as well as in PCT Application No. PCT/US89/03076 filed on Jul. 14, 1989. The purpose of the theoretically ideal stability plane as described in these applications was primarily to provide a neutral design that allows for natural foot and ankle biomechanics as close as possible to that between the foot and the ground, and to avoid the serious interference with natural foot and ankle biomechanics inherent in existing shoes.

The applicant's prior application on the sipe invention and the elaborations in this application are modifications of the inventions disclosed and claimed in the earlier applications and develop the application of the concept of the theoretically ideal stability plane to other shoe structures. Accordingly, it is a general object of the new invention to elaborate upon the application of the principle of the theoretically ideal stability plane to other shoe structures.

It is an overall objective of this application to show additional forms and variations of the general deformation sipes invention disclosed in the '509 and '579 applications, particularly showing its incorporation into the other inventions disclosed in the applicant's other applications.

These and other objects of the invention will become apparent from a detailed description of the invention which follows taken with the accompanying drawings.

BRIEF DESCRIPTION OF THE DRAWINGS

FIG. 1 shows, in frontal plane cross section at the heel portion of a shoe, a conventional modern running shoe with rigid heel counter and reinforcing motion control device and a conventional shoe sole. FIG. 1 shows that shoe when tilted 20 degrees outward, at the normal limit of ankle inversion.

FIG. 2 shows, in frontal plane cross section at the heel, the human foot when tilted 20 degrees outward, at the normal limit of ankle inversion.

FIG. 3 shows, in frontal plane cross section at the heel portion, the applicant's prior invention in pending U.S. application Ser. No. 07/424,509, filed Oct. 20, 1989, of a conventional shoe sole with sipes in the form of deformation slits aligned in the vertical plane along the long axis of the shoe sole.

FIG. 4 is a view similar to FIG. 3, but with the shoe tilted 20 degrees outward, at the normal limit of ankle inversion, showing that the conventional shoe sole, as modified according to pending U.S. application Ser. No. 07/424,509, filed Oct. 20, 1989, can deform in a manner paralleling the wearer's foot, providing a wide and stable base of support in the frontal plane.

FIG. 5 is a view repeating FIG. 9B of pending Application No. '509 showing deformation slits applied to the applicant's prior naturally contoured sides invention, with additional slits on roughly the horizontal plane to aid natural deformation of the contoured side.

FIG. 6A is a frontal plane cross section at the heel of a conventional shoe with a sole that utilizes both horizontal and sagittal plane slits;

FIG. 6B and FIG. 6C show other conventional shoe soles with other variations of horizontal plane deformation slits originating from the sides of the shoe sole.

FIG. 7 is a frontal plane cross section at the heel of a conventional shoe of the right foot utilizing horizontal plane deformation slits and tilted outward about 20 degrees to the normal limit of ankle motion.

FIG. 8 is a frontal plane cross section at the heel of a conventional shoe with horizontal plane sipes in the form of slits that have been enlarged to channels, which contain an elastic supportive material.

FIGS. 9A-C show a series of conventional shoe sole cross sections in the frontal plane at the heel utilizing both sagittal plane and horizontal plane sipes, and in which some or all of the sipes do not originate from any outer shoe sole surface, but rather are entirely internal; FIG. 9D shows a similar approach applied to the applicant's fully contoured design.

FIG. 10 shows, in frontal plane cross section at the heel portion of a shoe, the applicant's prior invention of a shoe sole with naturally contoured sides based on a theoretically ideal stability plane.

FIG. 11 shows, again in frontal plane cross section, the most general case of the applicant's prior invention, a fully contoured shoe sole that follows the natural contour of the bottom of the foot as well as its sides, also based on the theoretically ideal stability plane.

FIG. 12 shows, in frontal plane cross section at the heel, the use of a high density (d') midsole material on the naturally contoured sides and a low density (d) midsole material everywhere else to reduce side width.

DETAILED DESCRIPTION OF THE PREFERRED EMBODIMENTS

FIG. 1 shows a conventional athletic shoe in cross section at the heel, with a conventional shoe sole 22 having essentially flat upper and lower surfaces and having both a strong heel counter 141 and an additional reinforcement in the form of motion control device 142. FIG. 1 specifically illustrates when that shoe is tilted outward laterally in 20 degrees of inversion motion at the normal natural limit of such motion in the barefoot. FIG. 1 demonstrates that the conventional shoe sole 22 functions as an essentially rigid structure in the frontal plane, maintaining its essentially flat, rectangular shape when tilted and supported only by its outside, lower corner edge 23, about which it moves in rotation on the ground 43 when tilted. Both heel counter 141 and motion control device 142 significantly enhance and increase the rigidity of the shoe sole 22 when tilted. All three structures serve to restrict and resist deformation of the shoe sole 22 under normal loads, including standing, walking and running. Indeed, the structural rigidity of most conventional street shoe materials alone, especially in the critical heel area, is usually enough to effectively prevent deformation.

FIG. 2 shows a similar heel cross section of a barefoot tilted outward laterally at the normal 20 degree inversion maximum. In marked contrast to FIG. 1, FIG. 2 demonstrates that such normal tilting motion in the barefoot is accompanied by a very substantial amount of flattening deformation of the human foot sole, which has a pronounced rounded contour when unloaded, as will be seen in foot sole surface 29 later in FIG. 11.

FIG. 2 shows that in the critical heel area the barefoot maintains almost as great a flattened area of contact with the ground when tilted at its 20 degree maximum as when upright, as seen later in FIG. 3. In complete contrast, FIG. 1 indicate clearly that the conventional shoe sole changes in an instant from an area of contact with the ground 43 substantially greater than that of the barefoot, as much as 100 percent more when measuring in roughly the frontal plane, to a very narrow edge only in contact with the ground, an area of contact many times less than the barefoot. The unavoidable consequence of that difference is that the conventional shoe sole is inherently unstable and interrupts natural foot and ankle motion, creating a high and unnatural level of injuries, traumatic ankle sprains in particular and a multitude of chronic overuse injuries.

This critical stability difference between a barefoot and a conventional shoe has been dramatically demonstrated in the applicant's new and original ankle sprain simulation test described in detail in the applicant's earlier U.S. patent application Ser. No. 07/400,714, filed on Aug. 30, 1989 and was referred to also in both of his earlier applications previously noted here.

FIG. 3 shows, in frontal plane cross section at the heel, the applicant's prior invention of pending U.S. application Ser. No. 07/424,509, filed Oct. 20, 1989, the most clearcut benefit of which is to provide inherent stability similar to the barefoot in the ankle sprain simulation test mentioned above.

It does so by providing conventional shoe soles with sufficient flexibility to deform in parallel with the natural deformation of the foot. FIG. 3A indicates a conventional

shoe sole into which have been introduced deformation slits 151, also called sipes, which are located optimally in the vertical plane and on the long axis of the shoe sole, or roughly in the sagittal plane, assuming the shoe is oriented straight ahead.

The deformation slits 151 can vary in number beginning with one, since even a single deformation slit offers improvement over an unmodified shoe sole, though obviously the more slits are used, the more closely can the surface of the shoe sole coincide naturally with the surface of the sole of the foot and deform in parallel with it. The space between slits can vary, regularly or irregularly or randomly. The deformation slits 151 can be evenly spaced, as shown, or at uneven intervals or at unsymmetrical intervals. The optimal orientation of the deformation slits 151 is coinciding with the vertical plane, but they can also be located at an angle to that plane.

The depth of the deformation slits 151 can vary. The greater the depth, the more flexibility is provided. Optimally, the slit depth should be deep enough to penetrate most but not all of the shoe sole, starting from the bottom surface 31, as shown in FIG. 3A.

A key element in the applicant's invention is the absence of either a conventional rigid heel counter or conventional rigid motion control devices, both of which significantly reduce flexibility in the frontal plane, as noted earlier in FIG. 1, in direct proportion to their relative size and rigidity. If not too extensive, the applicant's prior sipe invention still provide definite improvement.

Finally, it is another advantage of the invention to provide flexibility to a shoe sole even when the material of which it is composed is relatively firm to provide good support; without the invention, both firmness and flexibility would continue to be mutually exclusive and could not coexist in the same shoe sole.

FIG. 4 shows, in frontal plane cross section at the heel, the applicant's prior invention of pending U.S. application Ser. No. 07/424,509, filed Oct. 20, 1989, showing the clearcut advantage of using the deformation slits 151 introduced in FIG. 3. With the substitution of flexibility for rigidity in the frontal plane, the shoe sole can duplicate virtually identically the natural deformation of the human foot, even when tilted to the limit of its normal range, as shown before in FIG. 2. The natural deformation capability of the shoe sole provided by the applicant's prior invention shown in FIG. 4 is in complete contrast to the conventional rigid shoe sole shown in FIG. 1, which cannot deform naturally and has virtually no flexibility in the frontal plane.

It should be noted that because the deformation sipes shoe sole invention shown in FIGS. 3 and 4, as well as other structures shown in the '509 application and in this application, allows the deformation of a modified conventional shoe sole to parallel closely the natural deformation of the barefoot, it maintains the natural stability and natural, uninterrupted motion of the barefoot throughout its normal range of sideways pronation and supination motion.

Indeed, a key feature of the applicant's prior invention is that it provides a means to modify existing shoe soles to allow them to deform so easily, with so little physical resistance, that the natural motion of the foot is not disrupted as it deforms naturally. This surprising result is possible even though the flat, roughly rectangular shape of the conventional shoe sole is retained and continues to exist except when it is deformed, however easily.

It should be noted that the deformation sipes shoe sole invention shown in FIGS. 3 and 4, as well as other structures

shown in the '509 application and in this application, can be incorporated in the shoe sole structures described in the applicant's pending U.S. application Ser. No. 07/469,313, as well as those in the applicant's earlier applications, except where their use is obviously precluded. Relative specifically to the '313 application, the deformation sipes can provide a significant benefit on any portion of the shoe sole that is thick and firm enough to resist natural deformation due to rigidity, like in the forefoot of a negative heel shoe sole.

Note also that the principal function of the deformation sipes invention is to provide the otherwise rigid shoe sole with the capability of deforming easily to parallel, rather than obstruct, the natural deformation of the human foot when load-bearing and in motion, especially when in lateral motion and particularly such motion in the critical heel area occurring in the frontal plane or, alternately, perpendicular to the subtalar axis, or such lateral motion in the important base of the fifth metatarsal area occurring in the frontal plane. Other sipes exist in some other shoe sole structures that are in some ways similar to the deformation sipes invention described here, but none provides the critical capability to parallel the natural deformation motion of the foot sole, especially the critical heel and base of the fifth metatarsal, that is the fundamental process by which the lateral stability of the foot is assured during pronation and supination motion. The optimal depth and number of the deformation sipes is that which gives the essential support and propulsion structures of the shoe sole sufficient flexibility to deform easily in parallel with the natural deformation of the human foot.

Finally, note that there is an inherent engineering trade-off between the flexibility of the shoe sole material or materials and the depth of deformation sipes, as well as their shape and number; the more rigid the sole material, the more extensive must be the deformation sipes to provide natural deformation.

FIG. 5 shows, in a portion of a frontal plane cross section at the heel, FIG. 9B of the applicant's prior invention of pending U.S. application Ser. No. 07/424,509, filed Oct. 20, 1989, showing the new deformation slit invention applied to the applicant's naturally contoured side invention, pending in U.S. application Ser. No. 07/239,667. The applicant's deformation slit design is applied to the sole portion **28b** in FIGS. 4B, 4C, and 4D of the earlier application, to which are added a portion of a naturally contoured side **28a**, the outer surface of which lies along a theoretically ideal stability plane **51**.

FIG. 5 also illustrates the use of deformation slits **152** aligned, roughly speaking, in the horizontal plane, though these planes are bent up, paralleling the sides of the foot and paralleling the theoretically ideal stability plane **51**. The purpose of the deformation slits **152** is to facilitate the flattening of the naturally contoured side portion **28b**, so that it can more easily follow the natural deformation of the wearer's foot in natural pronation and supination, no matter how extreme. The deformation slits **152**, as shown in FIG. 5 would, in effect, coincide with the lamination boundaries of an evenly spaced, three layer shoe sole, even though that point is only conceptual and they would preferably be of injection molding shoe sole construction in order to hold the contour better.

The function of deformation slits **152** is to allow the layers to slide horizontally relative to each other, to ease deformation, rather than to open up an angular gap as deformation slits or channels **151** do functionally. Consequently, deformation slits **152** would not be glued

together, just as deformation slits **152** are not, though, in contrast, deformation slits **152** could be glued loosely together with a very elastic, flexible glue that allows sufficient relative sliding motion, whereas it is not anticipated, though possible, that a glue or other deforming material of satisfactory consistency could be used to join deformation slits **151**. Optimally, deformation slits **152** would parallel the theoretically ideal stability plane **51**, but could be at an angle thereto or irregular rather than a curved plane or flat to reduce construction difficulty and therefore cost of cutting when the sides have already been cast.

The deformation slits **152** approach can be used by themselves or in conjunction with the shoe sole construction and natural deformation outlined in FIG. 9 of pending U.S. application Ser. No. 07/400,714; they can also be used in conjunction with shoe sole structures in pending U.S. application Ser. No. 07/416,478, filed on Oct. 3, 1989.

The number of deformation slits **152** can vary like deformation slits **151** from one to any practical number and their depth can vary throughout the contoured side portion **28b**. It is also possible, though not shown, for the deformation slits **152** to originate from an inner gap between shoe sole sections **28a** and **28b**, and end somewhat before the outside edge **53a** of the contoured side **28b**.

FIG. 6A shows, in a frontal plane cross section at the heel, a shoe sole with a combination like FIG. 5 of both sagittal plane deformation slits **151** and horizontal plane deformation slits **152**. It shows deformation slits **152** in the horizontal plane applied to a conventional shoe having a sole structure with moderate side flare and without either reinforced heel counter or other motion control devices that would obstruct the natural deformation of the shoe sole. The deformation slits **152** can extend all the way around the periphery of the shoe sole, or can be limited to one or more anatomical areas like the heel, where the typically greater thickness of the shoe sole otherwise would make deformation difficult; for the same reason, a negative heel shoe sole would need deformation enhancement of the thicker forefoot.

Also shown in FIG. 6A is a single deformation slit **151** in the sagittal plane extending only through the bottom sole **128**; even as a minimalist structure, such a single deformation sipe, by itself alone, has considerable effect in facilitating natural deformation, but it can be enlarged or supplemented by other sipes. The lowest horizontal slit **152** is shown located between the bottom sole **128** and the midsole **127**.

FIG. 6B shows, in frontal plane cross section at the heel, a similar conventional shoe sole structure with more and deeper deformation slits **152**, which can be used without any deformation slits **151**.

The advantage of horizontal plane deformation slits **152**, compared to sagittal plane deformation slits **151**, is that the normal weight-bearing load of the wearer acts to force together the sections separated by the horizontal slits so that those sections are stabilized by the natural compression, as if they were glued together into a single unit, so that the entire structure of the shoe sole reacts under compression much like one without deformation slits in terms of providing a roughly equivalent amount of cushioning and protection. In other words, under compression those localized sections become relatively rigidly supporting while flattened out directly under the flattened load-bearing portion of the foot sole, even though the deformation slits **152** allow flexibility like that of the foot sole, so that the shoe sole does not act as a single lever as discussed in FIG. 1.

In contrast, deformation sipes **151** are parallel to the force of the load-bearing weight of the wearer and therefore the shoe sole sections between those sipes **151** are not forced together directly by that weight and stabilized inherently, like slits **152**. Compensation for this problem in the form of firmer shoe sole material than are used conventionally may provide equivalently rigid support, particularly at the sides of the shoe sole, or deformation slits **152** may be preferable at the sides.

FIG. 6C shows, in frontal plane cross section at the heel, a similar conventional shoe sole structure horizontal plane deformation sipes **152** extending all the way from one side of the shoe sole to the other side, either coinciding with lamination layers—heel wedge **38**, midsole **127**, and bottom sole **128**—in older methods of athletic shoe sole construction or molded in during the more modern injection molding process. The point of the FIG. 6C design is that, if the laminated layers which are conventionally glued together in a rigidly fixed position can instead undergo sliding motion relative to each other, then they become flexible enough to conform to the ever changing shape of the foot sole in motion while at the same time continuing to provide about the same degree of necessary direct structural support.

Such separated lamination layers would be held together only at the outside edge by a layer of elastic material or fabric **180** bonded to the lamination layers **38**, **127** and **128**, as shown on the left side of FIG. 6C. The elasticity of the edge layer **180** should be sufficient to avoid inhibiting significantly the sliding motion between the lamination layers. The elastic edge layer **180** can also be used with horizontal deformation slits **152** that do not extend completely across the shoe sole, like those of FIGS. 6A and 6B, and would be useful in keeping the outer edge together, keeping it from flapping down and catching on objects, thus avoiding tripping. The elastic layer **180** can be connected directly to the shoe upper, preferably overlapping it.

The deformation slit structures shown in conventional shoe soles in FIG. 6 can also be applied to the applicant's quadrant sides, naturally contoured sides and fully contoured sides inventions, including those with greater or lesser side thickness, as well as to other shoe sole structures in his other prior applications already cited.

If the elastic edge layer **180** is not used, or in conjunction with its use, the lamination layers can be attached with a glue or other connecting material of sufficient elasticity to allow the shoe sole to deformation naturally like the foot.

FIG. 7 shows, in frontal plane cross section at the heel, a conventional shoe with horizontal plane deformation slits **152** with the wearer's right foot inverted 20 degrees to the outside at about its normal limit of motion. FIG. 7 shows how the use of horizontal plane deformation slits **152** allows the natural motion of the foot to occur without obstruction. The attachments of the shoe upper are shown conventionally, but it should be noted that such attachments are a major cause of the accordion-like effect of the inside edge of the shoe sole. If the attachments on both sides were move inward closer to the center of the shoe sole, then the slit areas would not be pulled up, leaving the shoe sole with horizontal plane deformation slits laying roughly flat on the ground with a convention, un-accordion-like appearance.

FIG. 8 shows, again in frontal plane cross section at the heel, a conventional shoe sole structure with deformation slits **152** enlarged to horizontal plane channels, broadening the definition to horizontal plane deformation sipes **152**, like the very broad definition given to sagittal plane deformations sipes **151** in both earlier applications, Nos. '509 and

'579. In contrast to sagittal plane deformation sipes **151**, however, the voids created by horizontal plane deformation sipes **152** must be filled by a material that is sufficiently elastic to allow the shoe sole to deform naturally like the foot while at the same time providing structural support.

Certainly, as defined most simply in terms of horizontal plane channels, the voids created must be filled to provide direct structural support or the areas with deformation sipes **152** would sag. However, just as in the case of sagittal plane deformation sipes **151**, which were geometrically defined as broadly as possible in the prior applications, the horizontal plane deformation sipes **152** are intended to include any conceivable shape and certainly to include any already conceived in the form of existing sipes in either shoe soles or automobile tire. For example, deformation sipes in the form of hollow cylindrical aligned parallel in the horizontal plane and sufficiently closely spaced would provide a degree of both flexibility and structural support sufficient to provide shoe sole deformation much closer to that of the foot than conventional shoe soles. Similarly, such cylinders, whether hollow or filled with elastic material, could also be used with sagittal plane deformation sipes, as could any other shape.

It should be emphasized that the broadest possible geometric definition is intended for deformation sipes in the horizontal plane, as has already been established for deformation sipes in the sagittal plane. There can be the same very wide variations with regard to deformation sipe depth, frequency, shape of channels or other structures (regular or otherwise), orientation within a plane or obliqueness to it, consistency of pattern or randomness, relative or absolute size, and symmetry or lack thereof.

The FIG. 8 design applies also to the applicant's earlier naturally contoured sides and fully contoured inventions, including those with greater or lesser side thickness; although not shown, the FIG. 8 design, as well as those in FIGS. 6 and 7, could use a shoe sole density variation like that in the applicant's pending U.S. application Ser. No. 07/416,478, filed on Oct. 3, 1989, as shown in FIG. 7 of the No. '579 application.

FIGS. 9A–C show a series of conventional shoe sole cross sections in the frontal plane at the heel utilizing, and in which some or all of the sipes do not originate from any outer shoe sole surface, but rather are entirely internal. Relative motion between internal surfaces is thereby made possible to facilitate the natural deformation of the shoe sole. The intent of the general invention shown in FIG. 9 is to create a similar but simplified and more conventional version of the some of the basic principles used in the unconventional and highly anthropomorphic invention shown in FIGS. 9 and 10 of the prior application No. '302, so that the resulting functioning is similar.

FIG. 9A shows a group of three lamination layers, but unlike FIG. 6C the central layer **188** is not glued to the other surfaces in contact with it; those surfaces are internal deformation slits in the sagittal plane **181** and in the horizontal plane **182**, which encapsulate the central layer **188**, either completely or partially. The relative motion between lamination layers at the deformation slits **181** and **182** can be enhanced with lubricating agents, either wet like silicone or dry like teflon, of any degree of viscosity; shoe sole materials can be closed cell if necessary to contain the lubricating agent or a non-porous surface coating or layer can be applied. The deformation slits can be enlarged to channels or any other practical geometric shape as sipes defined in the broadest possible terms.

The relative motion can be diminished by the use of roughened surfaces or other conventional methods, includ-

ing velcro-like attachments, of increasing the coefficient of friction between lamination layers. If even greater control of the relative motion of the central layer **188** is desired, as few as one or many more points can be glued together anywhere on the internal deformation slits **181** and **182**, making them discontinuous; and the glue can be any degree of elastic or inelastic.

In FIG. **9A**, the outside structure of the sagittal plane deformation sipes **181** is the shoe upper **21**, which is typically flexible and relatively elastic fabric or leather. In the absence of any connective outer material like the shoe upper shown in FIG. **9A** or the elastic edge material **180** of FIG. **6C**, just the outer edges of the horizontal plane deformation sipes **182** can be glued together.

FIG. **9B** shows another conventional shoe sole in frontal plane cross section at the heel with a combination similar to FIG. **9A** of both horizontal and sagittal plane deformation sipes that encapsulate a central section **188**. Like FIG. **9A**, the FIG. **9B** structure allows the relative motion of the central section **188** with its encapsulating outer midsole section **184**, which encompasses its sides as well as the top surface, and bottom sole **128**, both of which are attached at their common boundaries **183**.

This FIG. **9B** approach is analogous to that in FIG. **9** of the prior application No. '302, which is the applicant's fully contoured shoe sole invention with an encapsulated midsole chamber of a pressure-transmitting medium like silicone; in this conventional shoe sole case, however, the pressure-transmitting medium is a more conventional section of typical shoe cushioning material like PV or EVA, which also provides cushioning.

FIG. **9C** is also another conventional shoe sole in frontal plane cross section at the heel with a combination similar to FIGS. **9A** and **9B** of both horizontal and sagittal plane deformation sipes. However, instead of encapsulating a central section **188**, in FIG. **9C** an upper section **187** is partially encapsulated by deformation sipes so that it acts much like the central section **188**, but is more stable and more closely analogous to the actual structure of the human foot.

That structure was applied to shoe sole structure in FIG. **10** of prior application No. '302; the upper section **187** would be analogous to the integrated mass of fatty pads, which are U shaped and attached to the calcaneus or heel bone; similarly, the shape of the deformation sipes is U shaped in FIG. **9C** and the upper section **187** is attached to the heel by the shoe upper, so it should function in a similar fashion to the aggregate action of the fatty pads. The major benefit of the FIG. **9C** invention is that the approach is so much simpler and therefore easier and faster to implement than the highly complicated anthropomorphic design shown FIG. **10** of '302.

An additional note on FIG. **9C**: the midsole sides **185** are like the side portion of the encapsulating midsole **184** in FIG. **9B**.

FIG. **9D** shows in a frontal plane cross section at the heel a similar approach applied to the applicant's fully contoured design. FIG. **9D** is like FIG. **9A** of prior application No. '302, with the exception of the encapsulating chamber and a different variation of the attachment of the shoe upper to the bottom sole.

The left side of FIG. **9D** shows a variation of the encapsulation of a central section **188** shown in FIG. **9B**, but the encapsulation is only partial, with a center upper section of the central section **188** either attached or continuous with the upper midsole equivalent of **184** in FIG. **9B**.

The right side of FIG. **9D** shows a structure of deformation sipes like that of FIG. **9C**, with the upper midsole section **187** provided with the capability of moving relative to both the bottom sole and the side of the midsole. The FIG. **9D** structure varies from that of FIG. **9C** also in that the deformation sipe **181** in roughly the sagittal plane is partial only and does not extend to the upper surface **30** of the midsole **127**, as does FIG. **9C**.

FIGS. **10** and **11** show frontal plane cross sectional views of a shoe sole according to the applicant's prior inventions based on the theoretically ideal stability plane, taken at about the ankle joint to show the heel section of the shoe. In the figures, a foot **27** is positioned in a naturally contoured shoe having an upper **21** and a sole **28**. The shoe sole normally contacts the ground **43** at about the lower central heel portion thereof. The concept of the theoretically ideal stability plane, as developed in the prior applications as noted, defines the plane **51** in terms of a locus of points determined by the thickness (*s*) of the sole. The reference numerals are like those used in the prior which are incorporated by reference for the sake of completeness of disclosure, if necessary.

FIG. **10** shows, in a rear cross sectional view, the application of the prior invention showing the inner surface of the shoe sole conforming to the natural contour of the foot and the thickness of the shoe sole remaining constant in the frontal plane, so that the outer surface coincides with the theoretically ideal stability plane.

FIG. **11** shows a fully contoured shoe sole design of the applicant's prior invention that follows the natural contour of all of the foot, the bottom as well as the sides, while retaining a constant shoe sole thickness in the frontal plane.

The fully contoured shoe sole assumes that the resulting slightly rounded bottom when unloaded will deform under load and flatten just as the human foot bottom is slightly rounded unloaded but flattens under load; therefore, shoe sole material must be of such composition as to allow the natural deformation following that of the foot. The design applies particularly to the heel, but to the rest of the shoe sole as well. By providing the closest match to the natural shape of the foot, the fully contoured design allows the foot to function as naturally as possible. Under load, FIG. **11** would deform by flattening to look essentially like FIG. **10**. Seen in this light, the naturally contoured side design in FIG. **10** is a more conventional, conservative design that is a special case of the more general fully contoured design in FIG. **11**, which is the closest to the natural form of the foot, but the least conventional. The amount of deformation flattening used in the FIG. **10** design, which obviously varies under different loads, is not an essential element of the applicant's invention.

FIGS. **10** and **11** both show in frontal plane cross sections the essential concept underlying this invention, the theoretically ideal stability plane, which is also theoretically ideal for efficient natural motion of all kinds, including running, jogging or walking. FIG. **11** shows the most general case of the invention, the fully contoured design, which conforms to the natural shape of the unloaded foot. For any given individual, the theoretically ideal stability plane **51** is determined, first, by the desired shoe sole thickness (*s*) in a frontal plane cross section, and, second, by the natural shape of the individual's foot surface **29**.

For the special case shown in FIG. **10**, the theoretically ideal stability plane for any particular individual (or size average of individuals) is determined, first, by the given frontal plane cross section shoe sole thickness (*s*); second,

by the natural shape of the individual's foot; and, third, by the frontal plane cross section width of the individual's load-bearing footprint **30b**, which is defined as the upper surface of the shoe sole that is in physical contact with and supports the human foot sole.

The theoretically ideal stability plane for the special case is composed conceptually of two parts. Shown in FIG. **10**, the first part is a line segment **31b** of equal length and parallel to line **30b** at a constant distance (s) equal to shoe sole thickness. This corresponds to a conventional shoe sole directly underneath the human foot, and also corresponds to the flattened portion of the bottom of the load-bearing foot sole **28b**. The second part is the naturally contoured stability side outer edge **31a** located at each side of the first part, line segment **31b**. Each point on the contoured side outer edge **31a** is located at a distance which is exactly shoe sole thickness (s) from the closest point on the contoured side inner edge **30a**.

In summary, the theoretically ideal stability plane is the essence of this invention because it is used to determine a geometrically precise bottom contour of the shoe sole based on a top contour that conforms to the contour of the foot. This invention specifically claims the exactly determined geometric relationship just described.

It can be stated unequivocally that any shoe sole contour, even of similar contour, that exceeds the theoretically ideal stability plane will restrict natural foot motion, while any less than that plane will degrade natural stability, in direct proportion to the amount of the deviation. The theoretical ideal was taken to be that which is closest to natural.

Central midsole section **188** and upper section **187** in FIG. **9** must fulfill a cushioning function which frequently calls for relatively soft midsole material. Unlike the shoe sole structure shown in FIG. **9** of prior application No. '302, the shoe sole thickness effectively decreases in the FIG. **9** invention shown in this application when the soft central section is deformed under weight-bearing pressure to a greater extent than the relatively firmer sides.

In order to control this effect, it is necessary to measure it. What is required is a methodology of measuring a portion of a static shoe sole at rest that will indicate the resultant thickness under deformation. A simple approach is to take the actual least distance thickness at any point and multiply it times a factor for deformation or "give", which is typically measured in durometers (on Shore A scale), to get a resulting thickness under a standard deformation load. Assuming a linear relationship (which can be adjusted empirically in practice), this method would mean that a shoe sole midsection of 1 inch thickness and a fairly soft 30 durometer would be roughly functionally equivalent under equivalent load-bearing deformation to a shoe midsole section of ½ inch and a relatively hard 60 durometer; they would both equal a factor of 30 inch-durometers. The exact methodology can be changed or improved empirically, but the basic point is that static shoe sole thickness needs to have a dynamic equivalent under equivalent loads, depending on the density of the shoe sole material.

Since the Theoretically Ideal Stability Plane **51** has already been generally defined in part as having a constant frontal plane thickness and preferring a uniform material density to avoid arbitrarily altering natural foot motion, it is logical to develop a non-static definition that includes compensation for shoe sole material density. The Theoretically Ideal Stability Plane defined in dynamic terms would alter constant thickness to a constant multiplication product of thickness times density.

Using this restated definition of the Theoretically Ideal Stability Plane presents an interesting design possibility: the somewhat extended width of shoe sole sides that are required under the static definition of the Theoretically Ideal Stability Plane could be reduced by using a higher density midsole material in the naturally contoured sides.

FIG. **12** shows, in frontal plane cross section at the heel, the use of a high density (d') midsole material on the naturally contoured sides and a low density (d) midsole material everywhere else to reduce side width. To illustrate the principle, it was assumed in FIG. **12** that density (d') is twice that of density (d), so the effect is somewhat exaggerated to make clear, but the basic point is that shoe sole width can be reduced significantly by using the Theoretically Ideal Stability Plane with a definition of thickness that compensates for dynamic force loads. In the FIG. **12** example, about one fourth of an inch in width on each side is saved under the revised definition, for a total width reduction of one half inch, while rough functional equivalency should be maintained, as if the frontal plane thickness and density were each unchanging; again, the effect is exaggerated here to illustrate the point. Also, the line **51'** parallels the Theoretically Ideal Stability Plane **51** at half the distance from the outer surface of the foot **29**. Thus, for purposes of illustration, the difference between densities (d) and (d') is exaggerated. As shown in FIG. **12**, the boundary between sections of different density is indicated by the line **45**.

Note that the design in FIG. **12** uses low density midsole material, which is effective for cushioning, throughout that portion of the shoe sole that would be directly load-bearing from roughly 10 degrees of inversion to roughly 10 degrees, the normal range of maximum motion during running; the higher density midsole material is tapered in from roughly 10 degrees to 30 degrees on both sides, at which ranges cushioning is less critical than providing stabilizing support. Note also that the bottom sole is not shown in FIG. **12**, for purposes of simplification of the illustration. Accordingly, FIG. **12** illustrates a midsole bottom or outer surface **31'** and a midsole inner surface **30'**. However, a bottom sole must obviously also be included in the measurement of the shoe sole thickness and density; particularly with the bottom sole, consideration must also be given to the structure, specifically the tread pattern, which can have a large impact on density in particular areas.

The foregoing shoe designs meet the objectives of this invention as stated above. However, it will clearly be understood by those skilled in the art that the foregoing description has been made in terms of the preferred embodiments and various changes and modifications may be made without departing from the scope of the present invention which is to be defined by the appended claims.

What is claimed is:

1. A shoe sole for a shoe, comprising:

a midsole and a bottom sole;

the midsole having a midsole inner surface and a midsole outer surface which together circumscribe a midsole lateral side, a midsole medial side and a midsole middle portion located between the midsole lateral side and the midsole medial side,

the midsole lateral side comprising a lateral sidemost section and the midsole medial side comprising a medial sidemost section, each said sidemost section being located outside of a straight vertical line extending through the midsole at a respective sidemost extent of said midsole inner surface, as viewed in a shoe sole

13

frontal plane cross-section when the shoe sole is in an upright, unloaded condition;

at least one of the midsole lateral side and the midsole medial side comprising a convexly rounded midsole inner surface portion, the convexity being determined relative to a section of the midsole located directly adjacent to the convexly rounded midsole inner surface portion, as viewed in the shoe sole frontal plane cross-section when the shoe sole is in an upright, unloaded condition;

at least the midsole side having the at least one convexly rounded midsole inner surface portion comprising a concavely rounded midsole outer surface portion, the concavity being determined relative to an inner section of the midsole located directly adjacent to the concavely rounded midsole outer surface portion, as viewed in the shoe sole frontal plane cross-section when the shoe sole is in an upright, unloaded condition; an upper part of the midsole in said at least one midsole side which has the concavely rounded midsole outer surface portion extending up to above a level corresponding to lowest point of the midsole inner surface of the same midsole side,

the midsole comprising a first midsole portion which forms at least a part of the midsole middle portion and at least a part of the midsole side which has the concavely rounded midsole outer surface portion, as viewed in the shoe sole frontal plane cross-section when the shoe sole is in an upright, unloaded condition;

the midsole comprising a second midsole portion which forms at least a part of the midsole middle portion, as viewed in the shoe sole frontal plane cross-section when the shoe sole is in an upright, unloaded condition, said second midsole portion having at least a part with a midsole firmness that is different than a firmness of at least a part of said first midsole portion, all as measured in an area of the shoe sole adjacent and including said frontal plane cross-section during a shoe sole upright, unloaded condition;

the first and second midsole portions each having a contact surface which together form a boundary between said first and second midsole portions; and

a thickness of the first midsole portion gradually decreases from a first radial thickness to a lesser radial thickness, the radial thickness being measured from the boundary to an midsole outer surface of the first midsole portion located below a sidemost extent of a midsole side, and the radial thickness being measured along a line extending perpendicular to a line tangent to the boundary, all as viewed in the shoe sole frontal plane cross-section when the shoe sole is in an upright, unloaded condition.

2. The shoe sole construction as set forth in claim 1, wherein said first midsole portion comprises a greater midsole firmness than said second midsole portion, as measured in said area adjacent and including the frontal plane cross section during a shoe sole unloaded, upright condition.

3. The shoe sole construction as set forth in claim 1, wherein said frontal plane cross section is located in a heel area of the shoe sole.

4. The shoe sole construction as set forth in claim 1, wherein the concavely rounded midsole outer surface portion extends through the sidemost extent, all as viewed in the shoe sole frontal plane during a shoe sole unloaded, upright condition.

5. The shoe sole construction as set forth in claim 1, wherein both the lateral and medial sole sides comprise a

14

concavely rounded midsole outer surface portion, the concavely rounded midsole outer surface portions each extend through a sidemost extent of their respective midsole sides, all as viewed in the shoe sole frontal plane during a shoe sole unloaded, upright condition.

6. The shoe sole construction as set forth in claim 1, wherein a radial thickness between an inner surface of the first midsole portion and an outer surface of the first midsole portion tapers by decreasing gradually and substantially continuously from above the sidemost extent to the uppermost point of said midsole side having the rounded portions, as viewed in said shoe sole frontal plane cross section during a shoe sole unloaded, upright condition.

7. The shoe sole construction as set forth in claim 6, wherein the concavely rounded midsole outer surface portion extends through the sidemost extent, all as viewed in the shoe sole frontal plane during a shoe sole unloaded, upright condition.

8. The shoe sole construction as set forth in claim 6, wherein both the midsole lateral and midsole medial sides comprise a concavely rounded midsole outer surface portion extending through a sidemost extent of their respective midsole sides, all as viewed in the shoe sole frontal plane during a shoe sole unloaded, upright condition, the concavities being determined relative to an inner section of the midsole located directly adjacent to each respective concavely rounded midsole outer surface portions.

9. The shoe sole construction as set forth in claim 6, wherein said boundary comprises a concavely rounded section, as viewed in said shoe sole frontal plane cross section during a shoe sole upright, unloaded condition, the concavity being determined relative to a section of the second midsole portion located directly adjacent the concavely rounded section.

10. The shoe sole construction as set forth in claim 9, wherein the concavely rounded section extends through a sidemost extent of the second midsole portion adjacent the midsole side having the rounded portion, as viewed in said shoe sole frontal plane during a shoe sole unloaded, upright condition.

11. The shoe sole construction as set forth in claim 6, wherein the second midsole portion includes:

a concavely rounded outer surface portion extending through a sidemost extent of the second midsole portion adjacent the midsole lateral side, and

another concavely rounded outer surface portion extending through a sidemost extent of the second midsole portion adjacent the medial midsole side, all as viewed in said shoe sole frontal plane cross section during a shoe sole unloaded, upright condition, the concavities existing relative to an inner section of the second midsole portion located directly adjacent to each respective concavely rounded outer surface portion of the second midsole portion.

12. A shoe sole construction for a shoe, comprising:

a sole inner surface and a sole outer surface;

a sole lateral side, a sole medial side, and a sole middle portion located between the sole lateral side and the sole medial side,

the sole lateral side including a lateral sidemost section and the sole medial side including a medial sidemost section, each said section being located outside of a straight vertical line extending through the sole at a respective sidemost extent of said inner surface of the shoe sole, as viewed in said shoe sole frontal plane cross section during a shoe sole unloaded, upright condition;

15

a concavely rounded portion located in one of the sole lateral and medial sides, as viewed in a shoe sole frontal plane during a shoe sole unloaded, upright condition, the concavity existing with respect to an intended wearer's foot location in the shoe;

a midsole portion extending into the sidemost section of the sole side having the concavely rounded portion, and an upper part of said midsole portion extending up said sidemost section having the concavely rounded portion to above a level corresponding to a lowest point of an inner surface of the midsole portion located in the sidemost section having the concavely rounded portion, all as viewed in said shoe sole frontal plane cross section during a shoe sole unloaded, upright shoe condition; and

at least one internal slit located completely internal within said sole and extending into at least a part of said concavely rounded portion, as viewed in said shoe sole frontal plane cross section during a shoe sole unloaded, upright condition.

13. The shoe sole construction of claim 12, further including:

a second slit, the second slit extending substantially perpendicular to an adjacent portion of the sole inner and outer surfaces and located completely internal to the sole,

the first slit is connected to the second slit and extends generally parallel to said adjacent portion of the sole outer surface.

14. The shoe sole construction of claim 12, further including:

16

a second slit, the second slit extending substantially perpendicular to an adjacent portion of the sole inner and outer surfaces and located completely internal to the shoe, and

a third slit, the third slit extending substantially parallel to the adjacent portion of the sole inner surface and located completely internal to the shoe,

the first slit extends generally parallel to said adjacent portion of the sole outer surface.

15. The shoe sole construction of claim 14, wherein the first, second, and third slits are all connected to one another.

16. The shoe sole construction as set forth in claim 12, wherein said at least one internal slit is located between a bottom sole and said midsole portion.

17. A shoe sole construction for a shoe, particularly an athletic shoe, comprising:

at least one rounded side portion, as viewed in a shoe sole frontal plane during a shoe sole unloaded, upright condition; and

at least one internal slit that is completely internal within said sole and extends into at least a part of said at least one rounded side portion, as viewed in the shoe sole frontal plane cross section;

at least a portion of an internal surface created by the at least one internal slit is non-porous and separated from another internal surface of the at least one internal slit by at least one lubricating agent with a viscosity that affects relative motion between the internal surfaces.

* * * * *